

Low Noise, Cascadable Silicon Bipolar MMIC Amplifier

Technical Data

INA-02100

Features

- **Cascadable 50 Ω Gain Block**
- **Low Noise Figure:**
2.0 dB Typical at 0.5 GHz
- **High Gain:**
31.5 dB Typical at 0.5 GHz
25.0 dB Typical at 1.5 GHz
- **3 dB Bandwidth:**
DC to 1.0 GHz
- **Unconditionally Stable**
($k > 1$)

Description

The INA-02100 is a low-noise silicon bipolar Monolithic Microwave Integrated Circuit (MMIC) feedback amplifier chip. It is designed for narrow or wide bandwidth industrial and military applications that require high gain and low noise IF or RF amplification.

The INA series of MMICs is fabricated using HP's 10 GHz f_T , 25 GHz f_{MAX} , ISOSAT™-I silicon bipolar process which uses nitride self-alignment, submicrometer lithography, trench isolation, ion implantation, gold metallization and polyimide intermetal dielectric and scratch protection to achieve excellent performance, uniformity and reliability.

The recommended assembly procedure is gold-eutectic die attach at 400°C and either wedge or ball bonding using 0.7 mil gold wire.^[1]

Chip Outline^[1]

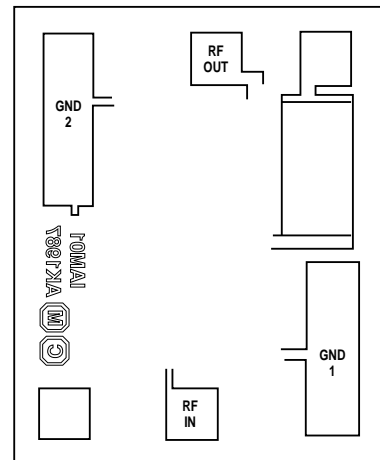

Notes:

1. See Application Note, "A005: Transistor Chip Use" for additional information.

Typical Biasing Configuration

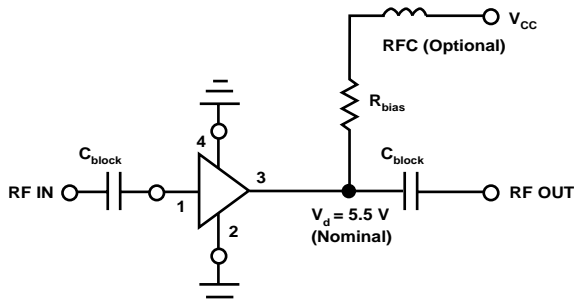

INA-02100 Absolute Maximum Ratings

Parameter	Absolute Maximum ^[1]
Device Current	50 mA
Power Dissipation ^[2,3]	400 mW
RF Input Power	+13 dBm
Junction Temperature	200°C
Storage Temperature	-65 to 200°C

Thermal Resistance^{[2]:}

$$\theta_{jc} = 60^\circ\text{C/W}$$

Notes:

1. Permanent damage may occur if any of these limits are exceeded.
2. $T_{\text{Mounting Surface}} (T_{\text{MS}}) = 25^\circ\text{C}$
3. Derate at 16.7 mW/°C for $T_{\text{MS}} > 176^\circ\text{C}$.

INA-02100 Electrical Specifications^[1,3], $T_A = 25^\circ\text{C}$

Symbol	Parameters and Test Conditions ^{[2]:} $I_d = 35 \text{ mA}$, $Z_0 = 50 \Omega$	Units	Min.	Typ.	Max.
G _P	Power Gain ($ S_{21} ^2$) f = 0.5 GHz	dB		31.5	
ΔG_P	Gain Flatness f = 0.1 to 1.0 GHz	dB		± 1.5	
f _{3 dB}	3 dB Bandwidth	GHz		1.0	
ISO	Reverse Isolation ($ S_{12} ^2$) f = 0.01 to 1.0 GHz	dB		39	
VSWR	Input VSWR f = 0.01 to 1.0 GHz			1.4:1	
	Output VSWR f = 0.01 to 1.0 GHz			1.5:1	
NF	50 Ω Noise Figure f = 0.5 GHz	dB		2.0	
P _{1 dB}	Output Power at 1 dB Gain Compression f = 0.5 GHz	dBm		11	
IP ₃	Third Order Intercept Point f = 0.5 GHz	dBm		23	
t _D	Group Delay f = 0.5 GHz	psec		350	
V _d	Device Voltage	V	4.0	5.5	7.0
dV/dT	Device Voltage Temperature Coefficient	mV/°C		+10	

Notes:

1. The recommended operating current range for this device is 30 to 40 mA. Typical performance as a function of current is on the following page.
2. RF performance of the chip is determined by packaging and testing 10 devices per wafer.
3. The values are the achievable performance for the INA-02100 mounted in a 70 mil stripline package.

INA-02100 Typical Scattering Parameters^[1] ($Z_0 = 50 \Omega$, $T_A = 25^\circ\text{C}$, $I_d = 5 \text{ mA}$)

Freq. GHz	S ₁₁		S ₂₁			S ₁₂			S ₂₂		k
	Mag	Ang	dB	Mag	Ang	dB	Mag	Ang	Mag	Ang	
0.01	0.06	-4	32.5	42.1	-2	-39.3	.011	14	.20	-1	1.27
0.05	0.05	-8	32.5	42.0	-8	-39.4	.011	12	.20	1	1.28
0.10	0.03	-46	32.3	41.3	-16	-37.9	.013	6	.20	-1	1.17
0.20	0.02	-52	31.8	39.0	-30	-39.2	.011	-4	.21	3	1.33
0.30	0.01	-46	31.1	36.2	-43	-38.8	.011	-12	.22	4	1.36
0.40	0.02	-44	30.4	33.3	-55	-40.4	.010	-2	.24	2	1.63
0.50	0.03	-35	29.7	30.7	-65	-39.3	.011	-17	.26	-1	1.56
0.60	0.06	-29	29.0	28.4	-74	-39.5	.011	-5	.28	-4	1.67
0.80	0.10	-41	27.9	24.8	-92	-38.1	.012	-9	.32	-14	1.58
1.00	0.17	-60	26.9	22.0	-108	-36.4	.015	-19	.34	-26	1.41
1.20	0.24	-73	26.0	19.9	-124	-35.5	.017	-16	.36	-40	1.32
1.40	0.30	-89	25.1	18.0	-141	-34.1	.020	-16	.38	-60	1.17
1.60	0.37	-103	24.1	16.0	-157	-32.6	.023	-30	.32	-91	1.19
1.80	0.42	-116	22.9	14.0	-174	-33.1	.022	-28	.26	-111	1.29
2.00	0.46	-128	21.5	12.0	171	-31.4	.027	-31	.22	-122	1.25
2.50	0.50	-146	18.3	8.2	142	-29.3	.034	-44	.19	-148	1.34
3.00	0.51	-162	14.6	5.4	116	-28.5	.038	-47	.15	178	1.83

Note:

1. S-parameters are de-embedded from 70 mil package measured data using the package model found in the DEVICE MODELS section of the *Communications Components Designer's Catalog*.

INA-02100 Typical Performance, $T_A = 25^\circ\text{C}$

(Unless otherwise noted: The values are the achievable performance for the INA-02100 mounted in a 70 mil stripline package.)

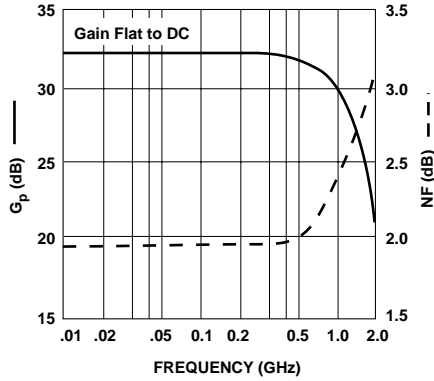

Figure 1. Typical Gain and Noise Figure vs. Frequency, $T_A = 25^\circ\text{C}$, $I_d = 35\text{ mA}$.

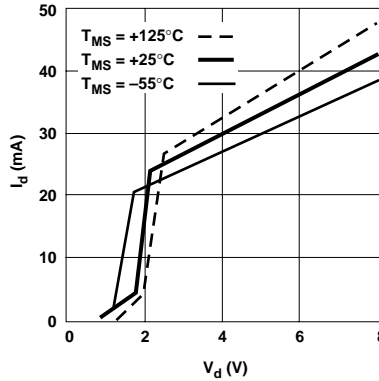

Figure 2. Device Current vs. Voltage.

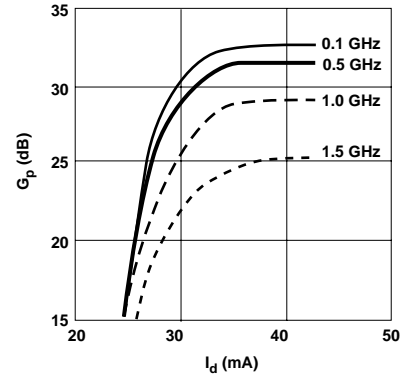

Figure 3. Power Gain vs. Current.

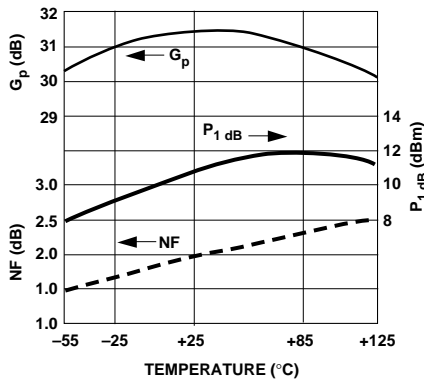

Figure 4. Output Power and 1 dB Gain Compression, NF and Power Gain vs. Case Temperature, $f = 0.1\text{ GHz}$, $I_d = 35\text{ mA}$.

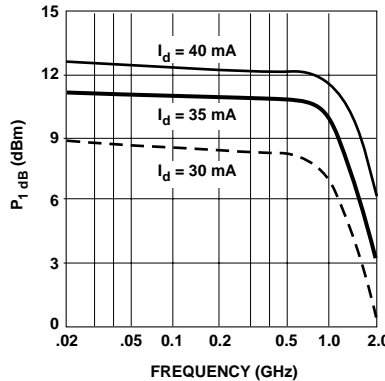

Figure 5. Output Power at 1 dB Gain Compression vs. Frequency.

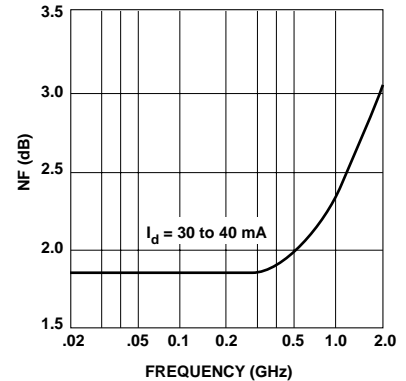
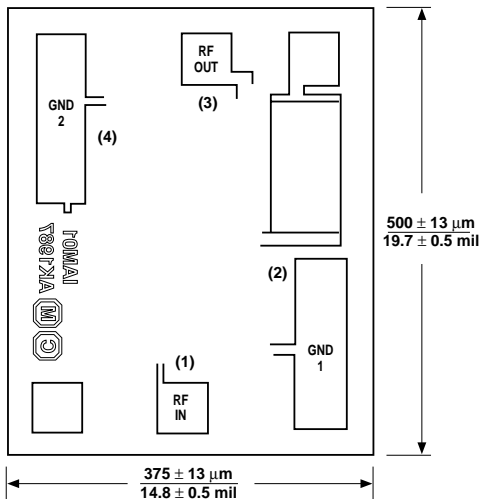

Figure 6. Noise Figure vs. Frequency.

INA-02100 Chip Dimensions



Chip thickness is $140\text{ }\mu\text{m}/5.5\text{ mil}$. Bond Pads are $41\text{ }\mu\text{m}/1.6\text{ mil}$ typical on each side. Note: Ground Bonding is Critical. Refer to Application Bulletin, "AB-0007: INA Bonding Configuration".